

GO CHAIR

OWNER'S MANUAL



The First Name in Travel Mobility™

Pride
Mobility Products Corp.

*Exeter, PA
St. Catharines, ON*

1-800-800-8586

www.pridemobility.com

SAFETY GUIDELINES

The symbols below are used throughout this owner's manual and on the Go-Chair to identify warnings and important information. It is very important for you to read them and understand them completely.



WARNING! Failure to follow designated procedures can cause either personal injury, component damage, or malfunction (black symbol on yellow triangle with black border).



MANDATORY! These actions should be performed as specified. Failure to perform mandatory actions can cause injury to personnel and/or damage to equipment (white symbol on blue dot).



PROHIBITED! These actions should be prohibited. These actions should not be performed at any time or in any circumstances. Performing a prohibited action can cause injury to personnel and/or damage to equipment (black symbol with red circle and red slash).

This product is not approved as a medical device and is coded by the SADMERC as A9270 (non-covered item).

Copyright © 2005
Pride Mobility Products Corp.
INFMANU2881/RevC/Aug05

C O N T E N T S

I. INTRODUCTION.....	4
II. SAFETY	6
III. YOUR GO-CHAIR.....	15
IV. ASSEMBLY/DISASSEMBLY	19
V. COMFORT ADJUSTMENTS.....	22
VI. BATTERIES AND CHARGING	24
VII. OPERATION.....	28
VIII. CARE AND MAINTENANCE	32
IX. WARRANTY	36

This owner’s manual is compiled from the latest specifications and product information available at the time of publication. We reserve the right to make changes as they become necessary. Any changes to our products may cause slight variations between the illustrations and explanations in this manual and the product you have purchased.

I . I N T R O D U C T I O N

SAFETY

WELCOME to Pride Mobility Products Corporation (Pride). The product you have purchased combines state of the art components with **safety**, comfort, and styling in mind. We are confident the design features will provide you with the conveniences you expect during your daily activities. Understanding how to **safely** operate and care for this product should bring you years of trouble free operations and service.

Read and follow all instructions, warnings, and notes in this manual and all other accompanying literature before attempting to operate this product for the first time. In addition, your **safety** depends upon you, as well as your provider or caretaker in using good judgement.

If there is any information in this manual which you do not understand, or if you require additional assistance for setup or operation, please contact an authorized Pride Provider. **Failure to follow the instructions, warnings, and notes in this manual and those located on your Pride product can result in personal injury or product damage and void Pride's product warranty.**

PURCHASER'S AGREEMENT

By accepting delivery of this product, you promise that you will not change, alter, or modify this product or remove or render inoperable or unsafe any guards, shields, or other safety features of this product; fail, refuse, or neglect to install any retrofit kits from time to time provided by Pride to enhance or preserve the safe use of this product.

INTERNET AND PRIVATE PURCHASES

The contents of this manual are based on the expectation that the authorized Pride Provider has properly fit the travel chair to the user and has assisted the user in the instruction process for the use of the product.

If you purchased the travel chair over the internet or from a previous owner and you have any questions about the safe use and/or maintenance of the product, please visit the Pride web site or contact an authorized Pride Provider.

INFORMATION EXCHANGE

We want to hear your questions, comments, and suggestions about this manual. We would also like to hear about the safety and reliability of your new Pride product, and about the service you received from an authorized Pride Provider. Please notify us of any change of address, so we can keep you apprised of important information about safety, new products, and new options that can increase your ability to use and enjoy your Pride product. Please feel free to contact us at the address below:

Pride Mobility Products Corporation
Attn: Customer Care Department
182 Susquehanna Ave.
Exeter, PA 18643-2694

NOTE: If you ever lose or misplace your product registration card or your copy of this manual, contact us and we will be glad to send you a new one immediately.

I . I N T R O D U C T I O N

PRIDE OWNERS CLUB

As an owner of a Pride product, you are encouraged to enroll in the Pride Owners Club. Complete and return your enclosed product registration card or visit Pride's web site at www.pridemobility.com.

From our home page, select "Owners Club" to enter a page dedicated to current and potential Pride product owners. You will gain access to interviews, stories, recreation ideas, daily living tips, product and funding information, and interactive message boards. These message boards invite you to communicate with other Pride customers as well as Pride representatives who are available to assist you with any questions or concerns.

Quick Reference Information:

Authorized Pride Provider: _____

Address: _____

Phone Number: _____

Purchase Date: _____

II. SAFETY

PRODUCT SAFETY SYMBOLS

The symbols below are used on the Go-Chair to identify warnings, mandatory actions, and prohibited actions. It is very important for you to read and understand them completely.



Corrosive chemicals contained in battery.



Explosive conditions.



Battery Charging - Using a charger rated for more than 4 amps peak may result in equipment damage.



Read and follow the information in the owner's manual.



Maximum seating weight.



Use only AGM or Gel-Cell batteries.



Locked and in drive mode.

Place unit on level ground and stand behind or to one side when changing from drive mode to freewheel mode or freewheel mode to drive mode.

Unlocked and in freewheel mode.

II. SAFETY



Do not use a cell phone, walkie/talkie, laptop, or other radio transmitter while operating.



Avoid exposure to rain, snow, ice, salt, or standing water whenever possible. Maintain and store in a clean and dry condition.



Removal of grounding prong can create electrical hazard. If necessary, properly install an approved 3-pronged adapter to an electrical outlet having 2-pronged plug access. Failure to heed could result in personal injury and/or property damage.



Prevent personal injury and equipment damage. Do not connect an extension cord to the AC/DC converter or the battery charger.

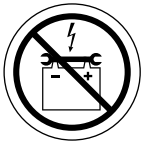

Contact with tools can cause electrical shock.



Do not remove anti-tip wheels.

II. SAFETY

SAFETY



MANDATORY! Do not operate your new Go-Chair for the first time without completely reading and understanding this owner's manual.

Your Go-Chair is a state-of-the-art life-enhancement device designed to increase mobility. Pride provides an extensive variety of products to best fit the individual needs of the Go-Chair user. Please be aware that the final selection and purchasing decision regarding the type of Go-Chair to be used is the responsibility of the Go-Chair user, who is capable of making such a decision.

There are certain situations, including some medical conditions, where the Go-Chair user will need to practice operating the Go-Chair in the presence of a trained attendant. A trained attendant can be defined as a family member or care professional specially trained in assisting a Go-Chair user in various daily living activities.

As you begin using your Go-Chair during daily activities, you will probably encounter situations in which you will need some practice. Simply take your time and you will soon be in full and confident control as you maneuver through doorways, on and off of elevators, up and down ramps, and over moderate terrain.

Below are some precautions, tips, and other safety considerations that will help the user become accustomed to operating the Go-Chair safely.

Modifications

Pride has designed and engineered your Go-Chair to provide maximum mobility and utility. A wide range of accessories is available from an authorized Pride Provider to further customize your Go-Chair to better suit your needs and/or preferences. However, under no circumstances should you modify, add, remove, or disable any feature, part, or function of your Go-Chair.



WARNING! Do not modify your Go-Chair in any way not authorized by Pride. Unauthorized modifications may result in personal injury and/or damage to your Go-Chair.

Pre-Ride Safety Check

Get to know the feel of your Go-Chair and its capabilities. Pride recommends that you perform a safety check before each use to make sure your Go-Chair operates smoothly and safely.

Perform the following inspections prior to using your Go-Chair:

- Check all electrical connections. Make sure they are tight and not corroded.
- Check the controller connection to the power base. Make sure it is secured properly.
- Check the brakes. See VIII. "Care and Maintenance."
- Check battery charge. See VI. "Batteries and Charging."

NOTE: *If you discover a problem, contact an authorized Pride Provider for assistance.*

II. SAFETY

Weight Limitations

Your Go-Chair is rated for a maximum weight capacity. Please refer to the specifications table for this limit.



WARNING! Exceeding the weight capacity voids your warranty and may result in personal injury and/or damage to your Go-Chair. Pride will not be held responsible for injuries and/or property damage resulting from failure to observe weight limitations.

WARNING! Do not carry passengers on your Go-Chair. Carrying passengers on your Go-Chair may result in personal injury and/or property damage.

Incline Information

More and more buildings have ramps with specified degrees of inclination, designed for easy and safe access. Some ramps may have turning switchbacks (180-degree turns) that require you to have good cornering skills on your Go-Chair.

- Proceed with extreme caution as you approach the downgrade of a ramp or other incline.
- Take wide swings with your travel chair's front wheels around any tight corners. If you do that, the travel chair's rear wheels will follow a wide arc, not cut the corner short, and not bump into or get hung up on any railing corners.
- When driving down a ramp, keep the travel chair's speed adjustment set to the slowest speed setting to ensure a safely controlled descent. See VII. "Operation."
- Avoid sudden stops and starts.

When climbing an incline, try to keep your Go-Chair moving. If you must stop, start up again slowly and then accelerate cautiously. When driving down an incline, set your Go-Chair to the slowest setting and drive in the forward direction only. If your Go-Chair starts to move down the incline faster than you anticipated or desired, allow it to come to a complete stop by releasing the joystick, then push the joystick forward slightly to ensure a safely controlled descent.

WARNING! When climbing an incline, do not zigzag or drive at an angle up the face of the incline. Drive your Go-Chair straight up the incline. This greatly reduces the possibility of a tip or a fall. Always exercise extreme caution when negotiating an incline.

WARNING! You should not travel up or down a potentially hazardous incline (i.e., areas covered with snow, ice, cut grass, or wet leaves).



WARNING! When on any sort of an incline or decline, never place the Go-Chair in freewheel mode while seated on it or standing next to it. Doing so may result in personal injury and/or damage to your Go-Chair.

WARNING! Never travel down an incline backwards. This may result in personal injury.

WARNING! Even though your Go-Chair is capable of climbing slopes greater than those illustrated in figure 1, do not, under any circumstances, exceed the incline guidelines or any other specifications presented in this manual. Doing so could cause instability in your Go-Chair, resulting in personal injury and/or damage to your Go-Chair.

In compliance with the Americans with Disabilities Act of 1990, all handicap public access ramps are required to have a maximum slope of 5° (8.7%). Therefore, Pride recommends that the maximum slope of an incline you attempt to safely ascend or descend on your Go-Chair does not exceed 5° (8.7%). See figure 1.



WARNING! Any attempt to climb or descend a slope steeper than 5° (8.7%) may put your Go-Chair in an unstable position and cause it to tip, resulting in personal injury.

II. SAFETY

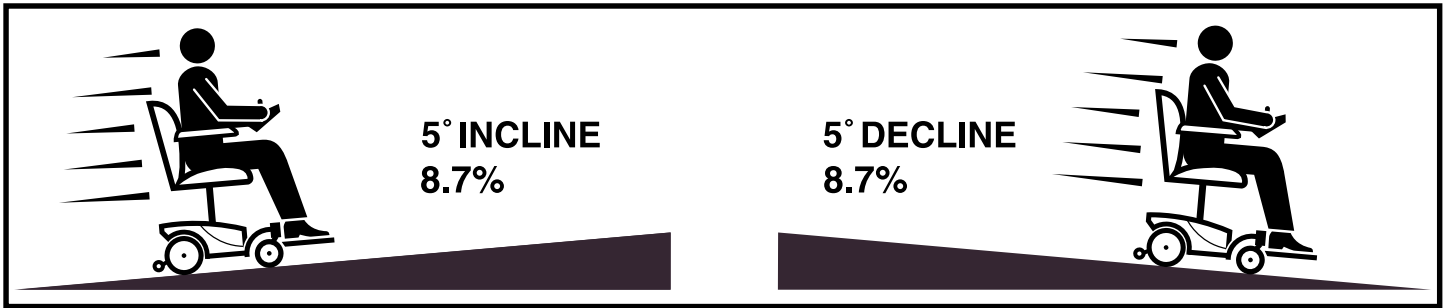

Figure 1. Maximum Safe Incline/Decline Angles

Braking Information

Your Go-Chair is equipped with two powerful brake systems:

1. Regenerative — uses electricity to rapidly slow the vehicle when the joystick returns to the center/stop position.
2. Disc Park Brake — activates mechanically after regenerative braking slows the vehicle to near stop, or when power is removed from the system for any reason.

Cornering Information

While your Go-Chair is equipped with two caster wheels and two anti-tip wheels, excessively high cornering speeds can still create the possibility of tipping. Factors which affect the possibility of tipping include, but are not limited to: cornering speed, steering angle (how sharply you are turning), uneven road surfaces, inclined road surfaces, riding from an area of low traction to an area of high traction (such as passing from a grassy area to a paved area – especially at high speed while turning), and abrupt directional changes. High cornering speeds are not recommended. If you feel that you may tip over in a corner, reduce your speed and steering angle (i.e., lessen the sharpness of the turn) to prevent your Go-Chair from tipping.



WARNING! When cornering sharply, reduce your speed. This greatly reduces the possibility of a tip or fall. To avoid personal injury and/or property damage, always exercise common sense when cornering.

Public Streets and Roadways



WARNING! You should not operate your Go-Chair on public streets and roadways. Be aware that it may be difficult for traffic to see you when you are seated on your Go-Chair. Obey all local pedestrian traffic rules. Wait until your path is clear of traffic, and then proceed with extreme caution.

Freewheel Mode

Your Go-Chair is equipped with two manual freewheel levers to allow for manual maneuverability by a trained attendant. For more information about how to place your Go-Chair into and out of freewheel mode, see III. “Your Go-Chair.”

WARNING! Do not use your Go-Chair in freewheel mode without an attendant present. Personal injury may result.



WARNING! Do not attempt to personally place your Go-Chair in freewheel mode while seated on it. Personal injury may result. Ask an attendant for assistance if necessary.

WARNING! Do not place your Go-Chair in freewheel mode while on an incline. The chair could roll uncontrollably on its own, causing personal injury.

II. SAFETY

Outdoor Driving Surfaces

Your Go-Chair is designed to provide optimum stability under normal driving conditions—dry, level surfaces composed of concrete, blacktop, or asphalt. However, Pride recognizes that there will be times when you will encounter other surface types. For this reason, your Go-Chair is designed to perform admirably on packed soil, grass, and gravel. Feel free to use your Go-Chair safely on lawns and in park areas.

- Reduce your travel chair's speed when driving on uneven terrain and/or soft surfaces.
- Avoid tall grass that can entangle the running gear.
- Avoid loosely packed gravel and sand.
- If you feel unsure about a driving surface, avoid that surface.

Stationary Obstacles (Steps, Curbs, etc.)

Proceed with extreme caution when driving near raised surfaces, unprotected ledges and/or drop-offs (curbs, porches, stairs, etc.). The correct method for approaching a curb is illustrated in figures 2 and 3.



WARNING! Do not attempt to have your Go-Chair climb or descend an obstacle that is higher than 1 inch unless you have the assistance of an attendant.

WARNING! Do not attempt to have your Go-Chair proceed backwards down any step, curb, or other obstacle. This may cause the Go-Chair to tip and cause personal injury.

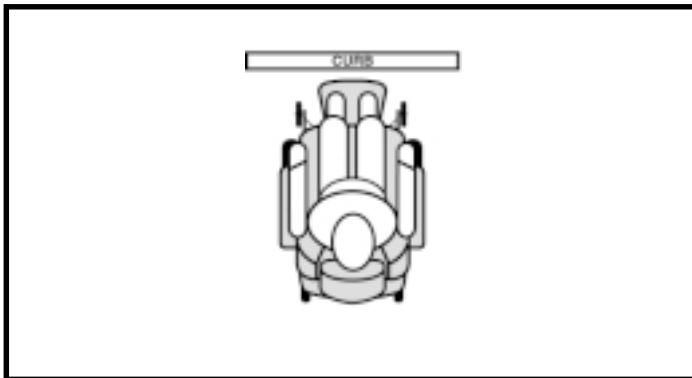

Figure 2. Correct Curb Approach



Figure 3. Incorrect Curb Approach

Stairs and Escalators

Travel chairs are not designed to travel up or down stairs or escalators. Always use an elevator.



WARNING! Never use your Go-Chair to negotiate steps or escalators. You may cause injury to yourself and to others and/or damage your Go-Chair.

II. SAFETY

Transfers

Transferring onto and off of your Go-Chair requires a good sense of balance. Always have an attendant present while learning to properly transfer yourself.

To eliminate the possibility of injury, Pride recommends that you or a trained attendant perform the following tasks before attempting a transfer:

- Turn off the power to the controller. See VII. “Operation.”
- Ensure your Go-Chair is not in freewheel mode. See III. “Your Go-Chair.”
- Turn both caster wheels toward the transfer destination to improve Go-Chair stability during transfer.
- Make sure both armrests are flipped up or removed from your Go-Chair.
- Flip up the foot platform; this will help to keep your feet from getting caught on the foot rigging during the transfer.
- Reduce the distance between your Go-Chair and the object you are transferring onto.

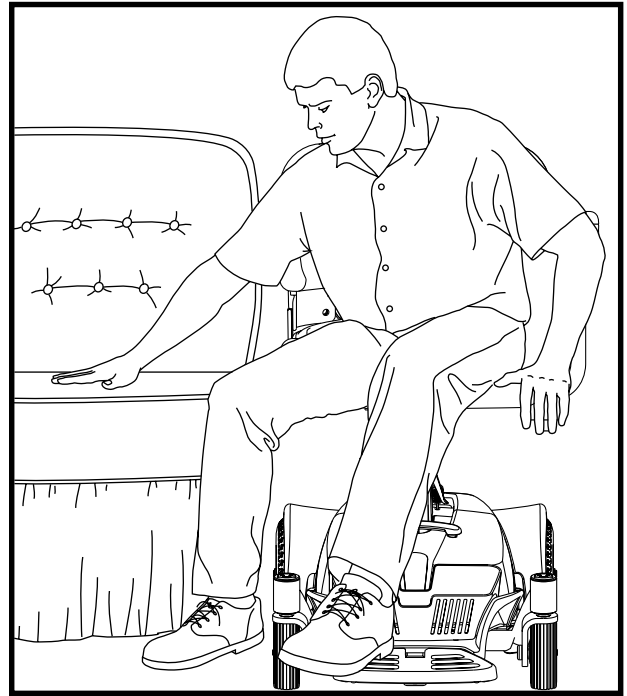

Figure 4. Ideal Transfer Position

WARNING! Before transferring, position yourself as far back as possible in the Go-Chair seat to prevent the Go-Chair from tipping forward during transfer and causing injury.



WARNING! Avoid using your armrests for weight bearing purposes. Such use may cause the Go-Chair to tip and cause personal injury.

WARNING! Avoid putting all of your weight on the foot riggings. Such use may cause the Go-Chair to tip and cause personal injury.

Doors

- Determine if the door opens toward or away from you.
- Drive your Go-Chair gently and slowly forward to push the door open, or drive your Go-Chair gently and slowly backwards to pull the door open.

Elevators

Modern elevators have a door edge safety mechanism that, when pushed, reopens the elevator door(s).

- If you are in the doorway of an elevator when the door(s) begin to close, push on the rubber door edge or allow the rubber door edge to contact the Go-Chair and the door will reopen.
- Use care that pocketbooks, packages, or Go-Chair accessories do not become caught in elevator doors.

Lift/Elevation Products

If you will be traveling with your Go-Chair, you may find it necessary to use a lift/elevation product to aid in transportation. Pride recommends that you closely review the instructions, specifications, and safety information set forth by the manufacturer of the lift/elevation product before using that product.

II. SAFETY

Inclement Weather Precautions

Exposure of your Go-Chair to inclement weather conditions should be avoided whenever possible. If suddenly caught up in rain, snow, severe cold or heat while operating your Go-Chair proceed to shelter at the earliest opportunity. Thoroughly dry your Go-Chair before storing, charging, or operating your Go-Chair.



WARNING! Operating in rain, snow, salt, mist/spray conditions, and on icy/slippery surfaces can cause personal injury and/or damage to the Go-Chair and electrical system. Maintain and store your Go-Chair in a dry and clean condition.

Motor Vehicle Transport

Currently, there are no standards approved for tie-down systems in a moving vehicle of any type to transport a person while seated in a Go-Chair.

Positioning Belts

WARNING! If you require a positioning belt to safely operate your Go-Chair, make sure it is fastened securely. Serious personal injury may result if you fall from the Go-Chair.



WARNING! The positioning belt is not designed for use as a seat belt in a motor vehicle. Nor is your Go-Chair suitable for use as a seat in any vehicle. Anyone traveling in a vehicle should be properly belted into seats approved by the vehicle manufacturer.

WARNING! Do not sit on your Go-Chair while it is in a moving vehicle. Personal injury and/or property damage may result.

WARNING! Always be sure your Go-Chair and its batteries are properly secured when it is being transported. Failure to do so may result in personal injury and/or damage to your Go-Chair.

Reaching and Bending

Never reach, lean, or bend while driving your Go-Chair. If it is absolutely necessary to reach, lean, or bend while seated on your Go-Chair, it is important to maintain a stable center of gravity and keep the Go-Chair from tipping. Pride recommends that the Go-Chair user determine his/her personal limitations and practice bending and reaching in the presence of a attendant.



WARNING! Do not bend, lean, or reach for objects if you have to pick them up from the floor by reaching down between your knees. Movements such as these may change your center of gravity and the weight distribution of the Go-Chair. This may cause your Go-Chair to tip, possibly resulting in personal injury. Keep your hands away from the tires when driving.

Batteries

In addition to following the warnings below, be sure to comply with all other battery handling information. For more information about your travel chair's batteries, see VI. "Batteries and Charging."

WARNING! Go-Chair batteries are heavy. See specifications table. If you are unable to lift that much weight, be sure to get help. Lifting beyond your capacity can result in personal injury.



WARNING! Battery posts, terminals, and related accessories contain lead and lead compounds. Wash hands after handling.

WARNING! Always protect the batteries from freezing and never charge a frozen battery. Charging a frozen battery may result in personal injury and/or damage to the battery.

II. SAFETY

Removable Parts



WARNING! Do not attempt to lift or move a Go-Chair by any of its removable parts. Personal injury and/or damage to the Go-Chair may result.

Preventing Unintended Movement



WARNING! If you anticipate being seated in a stationary position for an extended period of time, turn off the power. This will prevent unexpected motion from inadvertent joystick contact. This will also eliminate the possibility of unintended chair movement from electromagnetic (EM) sources. Failure to do so may result in personal injury.

Prescription Drugs/Physical Limitations

Users must exercise care and common sense when operating a Go-Chair. This includes awareness of safety issues when taking prescribed or over-the-counter drugs or when the user has specific physical limitations.



WARNING! Consult your physician if you are taking prescribed or over-the-counter medication or if you have certain physical limitations. Some medications and limitations may impair your ability to operate your Go-Chair in a safe manner.

Alcohol

The Go-Chair user must exercise care and common sense when operating his/her Go-Chair. This includes awareness of safety issues while under the influence of alcohol.



WARNING! Do not operate your Go-Chair while you are under the influence of alcohol, as this may impair your ability to operate your Go-Chair in a safe manner.

Electromagnetic and Radio Frequency Interference (EMI/RFI)



WARNING! Laboratory tests have shown that electromagnetic and radio frequency waves can have an adverse affect on the performance of electrically-powered mobility vehicles.

Electromagnetic and Radio Frequency Interference can come from sources such as cellular phones, mobile two-way radios (such as walkie-talkies), radio stations, TV stations, amateur radio (HAM) transmitters, wireless computer links, microwave signals, paging transmitters, and medium-range mobile transceivers used by emergency vehicles. In some cases, these waves can cause unintended movement or damage to the control system. Every electrically-powered mobility vehicle has an immunity (or resistance) to EMI. The higher the immunity level, the greater the protection against EMI. This product has been tested and has passed at an immunity level of 20 V/m.

WARNING! Be aware that cell phones, two-way radios, laptops and other types of radio transmitters may cause unintended movement of your electrically-powered mobility vehicle due to EMI. Exercise caution when using any of these items while operating your mobility vehicle and avoid coming into close proximity of radio and TV stations.



WARNING! The addition of accessories or components to the electrically-powered mobility vehicle can increase the susceptibility of the vehicle to EMI. Do not modify your travel chair in any way not authorized by Pride.

WARNING! The electrically-powered mobility vehicle itself can disturb the performance of other electrical devices located nearby, such as alarm systems.

NOTE: For further information on EMI/RFI, go to the Resource Center on www.pridemobility.com. If unintended motion or brake release occurs, turn your travel chair off as soon as it is safe to do so. Call Pride at 800-424-8205 to report the incident.

III. YOUR GO-CHAIR

THE GO-CHAIR

The Go-Chair has two main assemblies: the seat assembly and the power base assembly. See figure 5. Typically, the seat assembly includes the armrests, seatback, and seat base. The power base assembly includes the two motors, two drive wheels, two caster wheels, two anti-tip wheels, two batteries, and a foot platform. See figures 5 and 6.

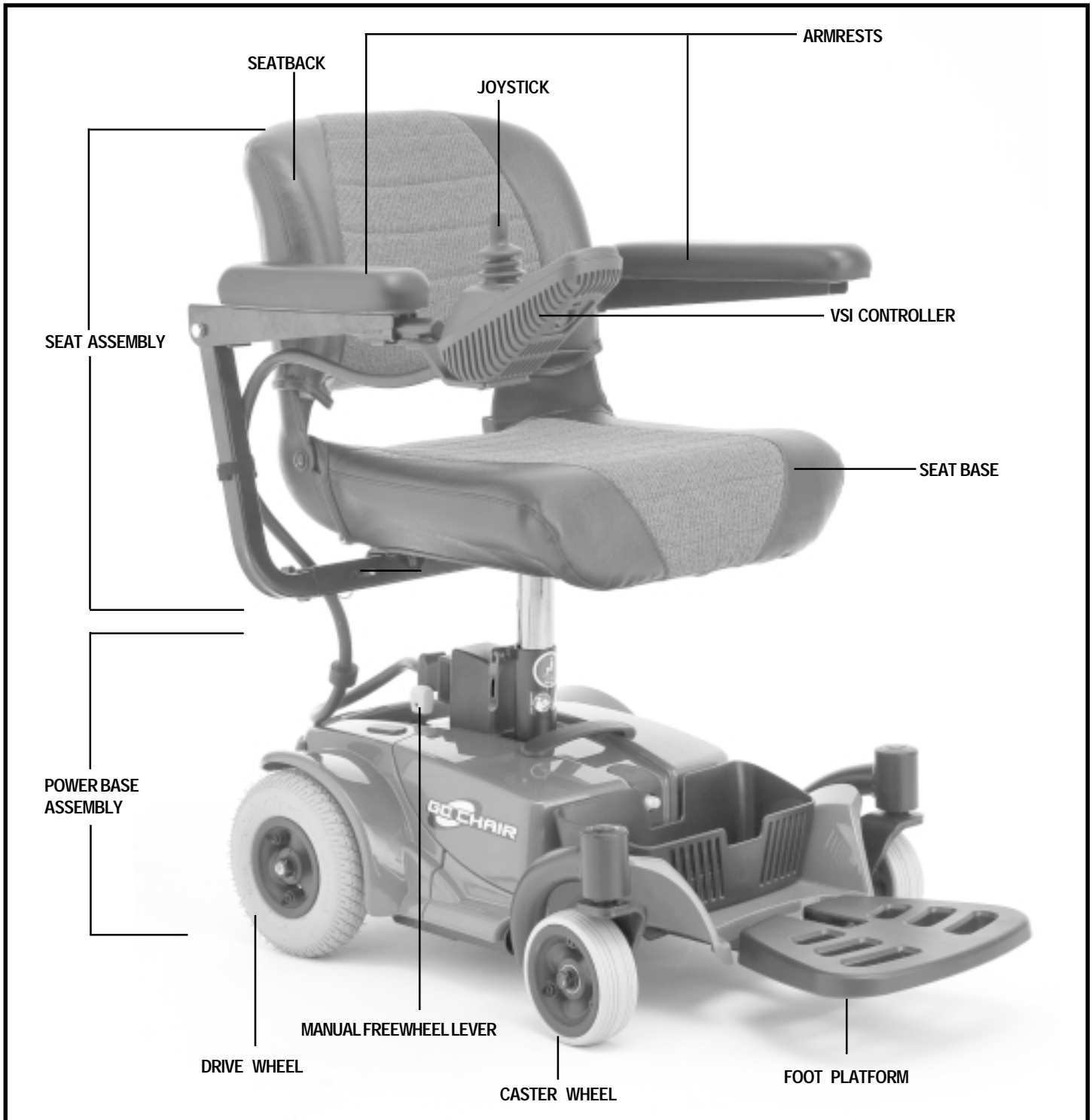

Figure 5. The Go-Chair

III. YOUR GO-CHAIR

GO-CHAIR SPECIFICATIONS

Suspension:	Limited
Drive Wheels:	8 in., solid
Front Caster Wheels:	5 in., solid
Rear Anti-tip Wheels:	2 in., solid
Maximum Speed:	Up to 3.5 mph*
Brakes:	"Intelligent Braking" electronic regenerative, disc park brake
Ground Clearance:	2.5 in.
Turning Radius:	19 in.
Overall Size:	Length: 27 in. Width: 19 in.
Seating:	Molded plastic with cushion
Drivetrain:	Two motor, rear -wheel drive
Batteries:	Two (2) 12AH, 12 volt, deep-cycle
Range:	Up to 10 miles*
Battery Charger:	2-amp, off-board
Electronics:	50-amp PG Drives VSI Controller
Weight Capacity:	250 lbs.
Component Weights:	Base: Front - 22.5 lbs./Rear - 34.5 lbs. Seat: 25 lbs. Batteries: 20 lbs. (total weight of battery pack)

*Depending on user weight and terrain.

III. YOUR GO-CHAIR

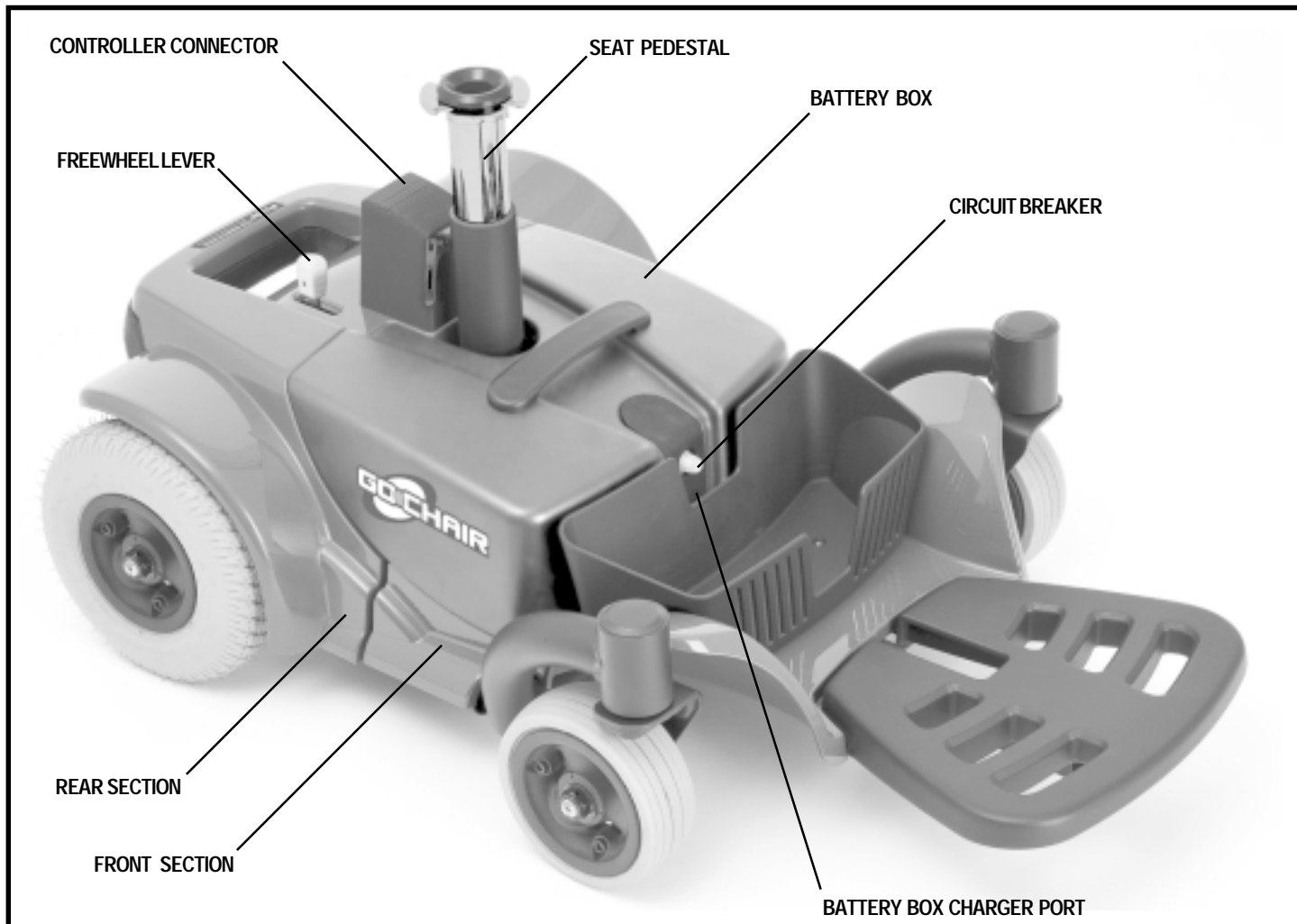

Figure 6. The Go-Chair Power Base

ELECTRICAL COMPONENTS

The electrical components are located on the power base. The main circuit breaker is located on the front of the battery box. The controller connector is located on the back of the power base. See figure 6.

Controller Connector: This is where the controller connects to the batteries and the motors.

Battery Box Charger Port: This enables you to charge the batteries when the battery box is removed from the power base. See VI. “Batteries and Charging.”

NOTE: *The Go-Chair battery box can be charged on or off of the power base. The battery box charger port should only be used when the battery box has been removed from the power base.*

Main Circuit Breaker: The main circuit breaker is a safety feature built into your Go-Chair. When the batteries and the motors are heavily strained (e.g., from excessive loads), the main circuit breaker trips to prevent damage to the motors and the electronics. If the circuit trips, allow your Go-Chair to “rest” for approximately one minute. Next, push in the circuit breaker button, turn on the controller, and continue normal operation. If the main circuit breaker continues to trip repeatedly, contact an authorized Pride Provider.

III. YOUR GO-CHAIR

MANUAL FREEWHEEL LEVERS

The Go-Chair has a manual freewheel lever on each motor. Manual freewheel levers enable you to disable the drive system in order to push the chair.



WARNING! Do not use the Go-Chair while the drive system is disabled! Do not disable the drive system when the Go-Chair is on an incline, as the unit could roll on its own, causing injury!

NOTE: *The batteries will not charge in freewheel mode unless the battery box is removed from the power base.*

NOTE: *You must turn off the power before disabling the drive systems, otherwise you may get an error code on the controller. To clear this code, turn off the controller and place the Go-Chair in drive mode. Then turn on the controller. The error message should be cleared. If not, contact an authorized Pride Provider.*

To engage or disengage the drive system:

1. Locate the levers on the rear section of the power base. See figure 7.
2. Push the two levers forward to enable the drive system.
3. Pull the two levers rearward to disable the drive system.



WARNING! It is important to remember that when your Go-Chair is in freewheel mode, the braking system is disengaged.

ANTI-TIP WHEELS

The anti-tip wheels are an integral and important safety feature of your Go-Chair. Do not, under any circumstances, remove the anti-tip wheels from your Go-Chair. See figure 7.

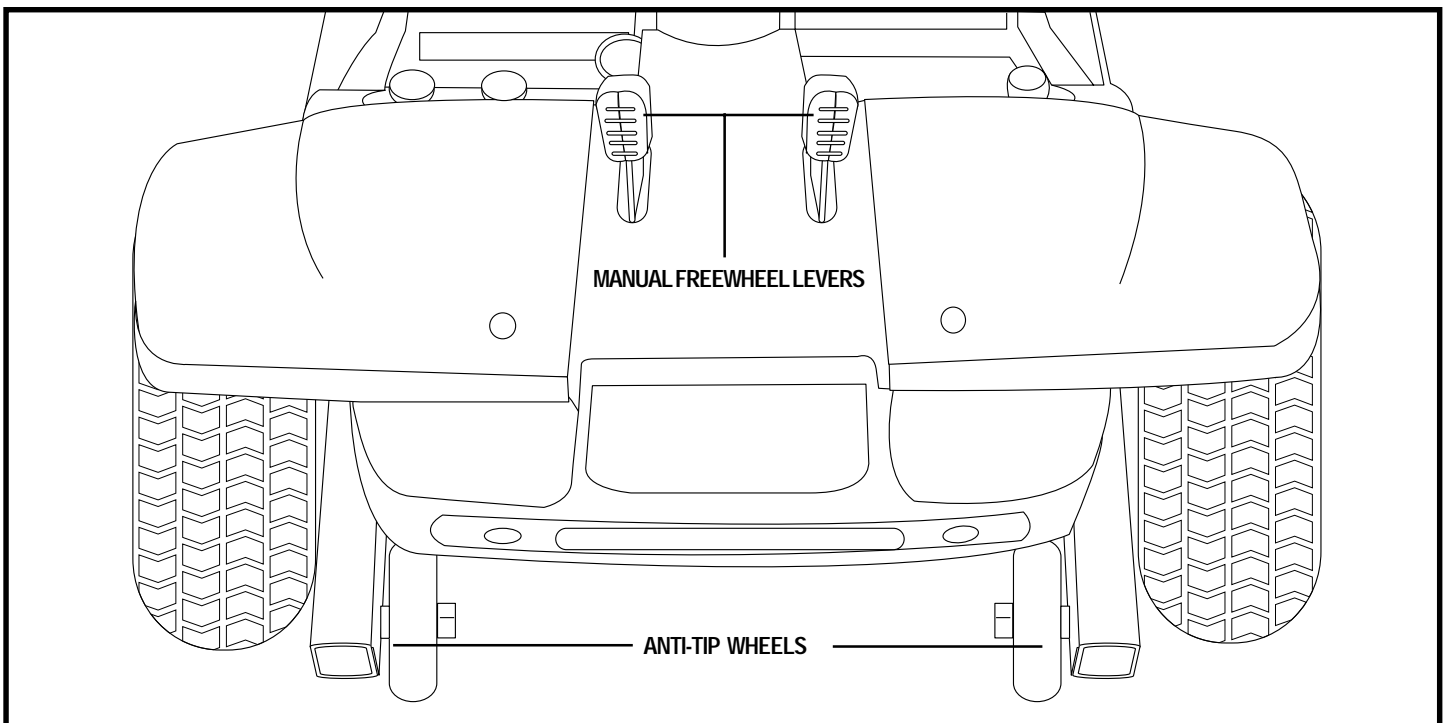

Figure 7. Back of Power Base

IV. ASSEMBLY/DISASSEMBLY

INITIAL ASSEMBLY

Your Go-Chair may require some assembly either before initial use or after transportation. It may also require disassembly to make some comfort adjustments. Figure 8 details those parts of the Go-Chair that are designed to be disassembled and assembled by an end user or by a qualified caregiver before using the product or making comfort adjustments. There are two hex keys provided for use with controller installation and adjustment and foot platform adjustment.

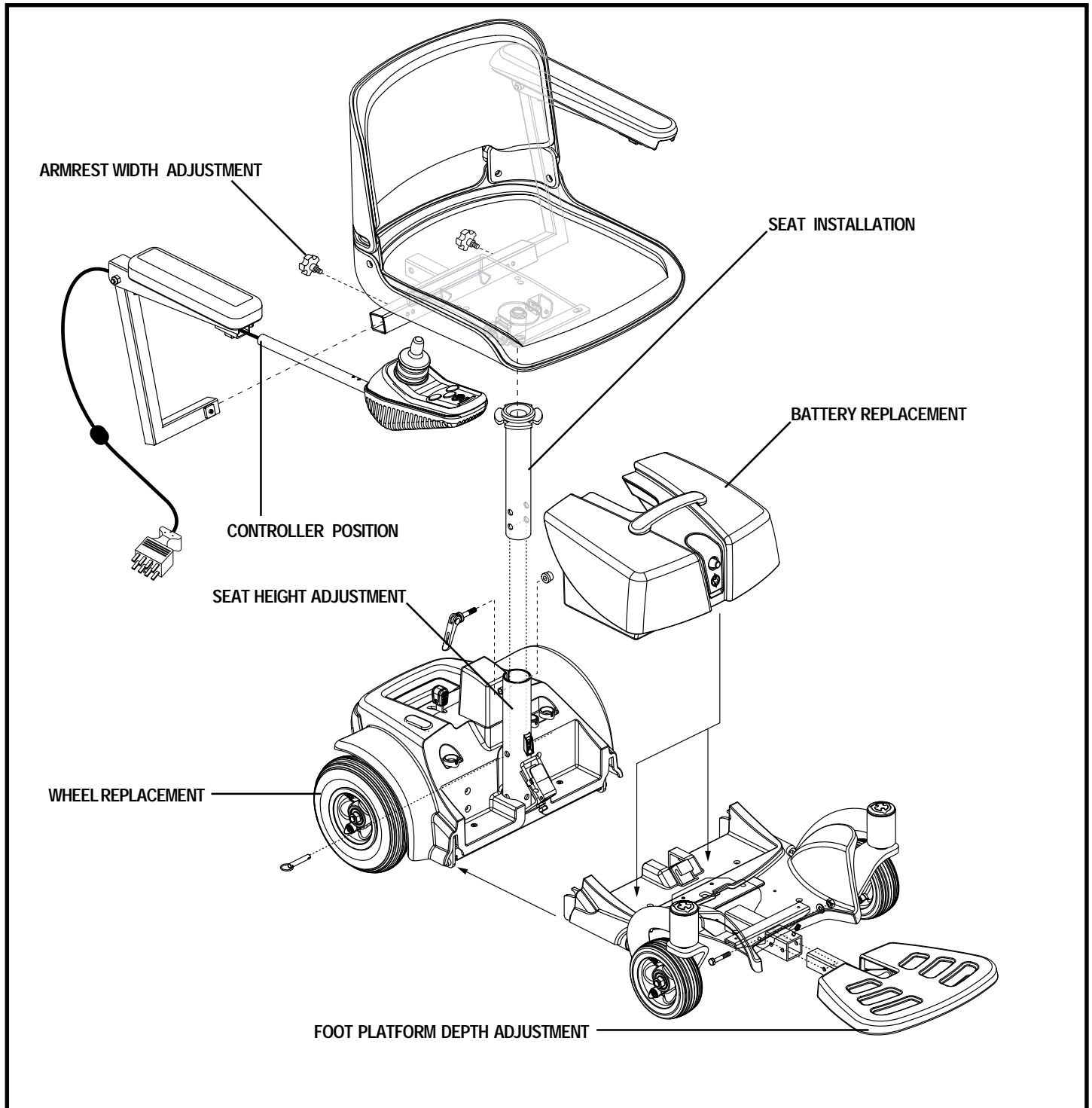

Figure 8. Go-Chair Assembly View

IV. ASSEMBLY/DISASSEMBLY

SEAT INSTALLATION

It may be necessary to install the seat either prior to initial operation or after transporting your Go-Chair. The seat is attached to the power base by a height-adjustable seat pedestal.



WARNING! Do not pick up the seat frame by the armrests. They are free to pivot, and you may lose control of the seat if they do so, resulting in personal injury or damage to the chair.

To install the seat:

1. Adjust the seat height if necessary. See V. “Comfort Adjustments.”
2. Set the seat onto the seat pedestal. See figure 9.
3. Install the controller into the armrest, and tighten the setscrew under the armrest.
4. Plug the controller connector into the power base. See figure 6.

DISASSEMBLY

The Go-Chair disassembles into four components: the seat, the battery box, the rear section of the power base and the front section of the power base. See figure 10.

To disassemble the Go-Chair:

1. Turn off power to the controller. See VII. Operation.
2. Place the Go-Chair in drive mode. See III. “Your Go-Chair.”
3. Disconnect the controller from the power base.
4. Remove the seat.
5. Grasp the battery box handle and lift up to disengage the box from the power base, then tilt the box forward slightly and pull it away from the power base.
6. Push in the toggle latch release button while pulling forward on the toggle latch. See figure 11.
7. Rotate the toggle latch buckle over the top of the toggle latch until it snaps into its retainer. See figure 12.
8. Lift the front section up and off of the rear section.

ASSEMBLY

1. Tilt the Go-Chair rear section rearward onto the anti-tip wheels. See figure 13.
2. While holding the front section parallel to the floor, align the curved locking brackets on the front section with the corresponding pegs on the rear section. See figure 14.

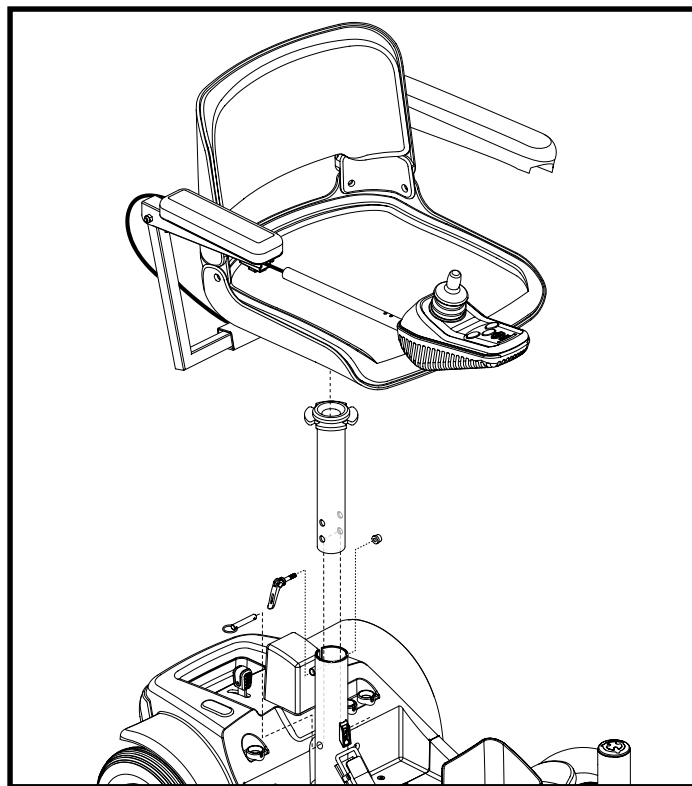

Figure 9. Seat Installation

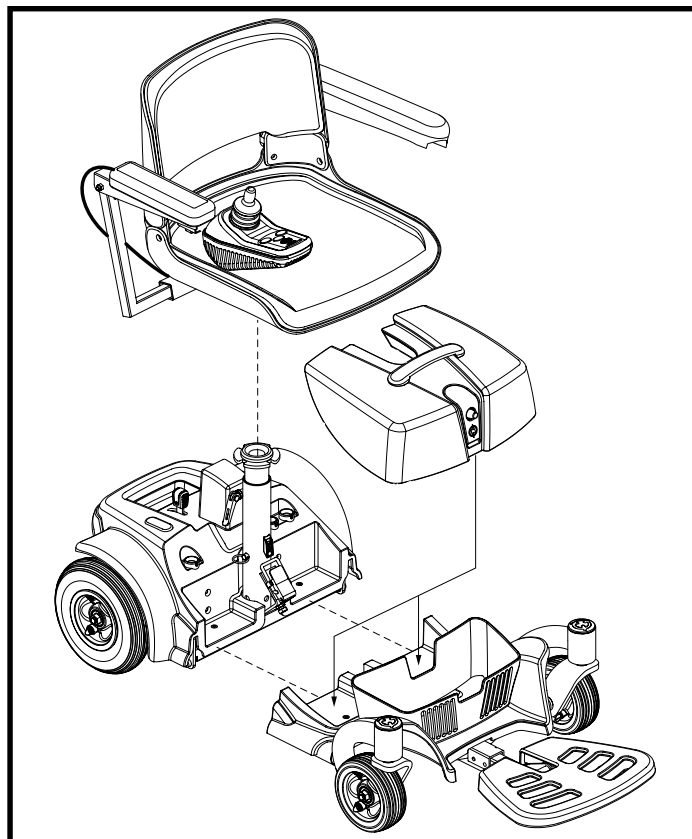

Figure 10. Go-Chair Components

IV. ASSEMBLY/DISASSEMBLY

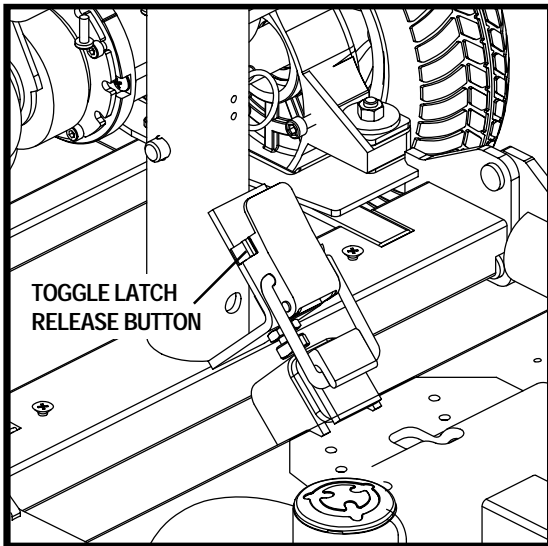

Figure 11. Toggle Latch Closed

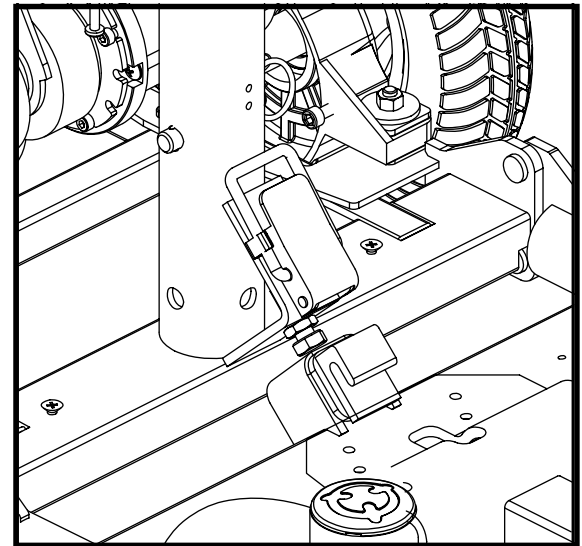

Figure 12. Toggle Latch Open

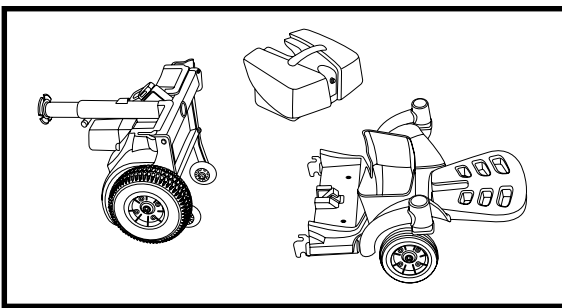

Figure 13. Rear Section Positioning

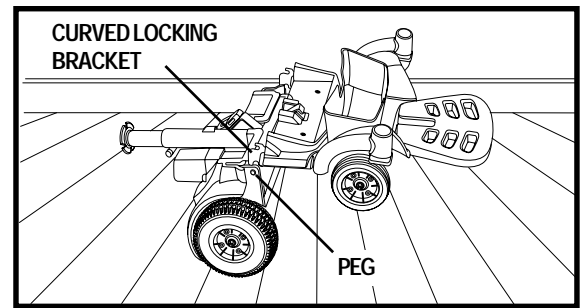

Figure 14. Align Frame Sections

3. Grasp the foot platform and lift the front section to a vertical position on the rear section. See figure 15.
4. Secure the toggle latch to the locked position. See figure 11.



WARNING! Prevent product damage! Ensure that the toggle latch buckle is securely fastened to the retainer before operating the Go-Chair.

5. Grasp the foot platform and lower the assembled frame sections to the floor.
6. With the battery box tilted forward slightly, place it on the power base, then push the back of the battery box down until it is firmly in place.
7. Install the seat and plug the controller connector into the power base. See figure 6.

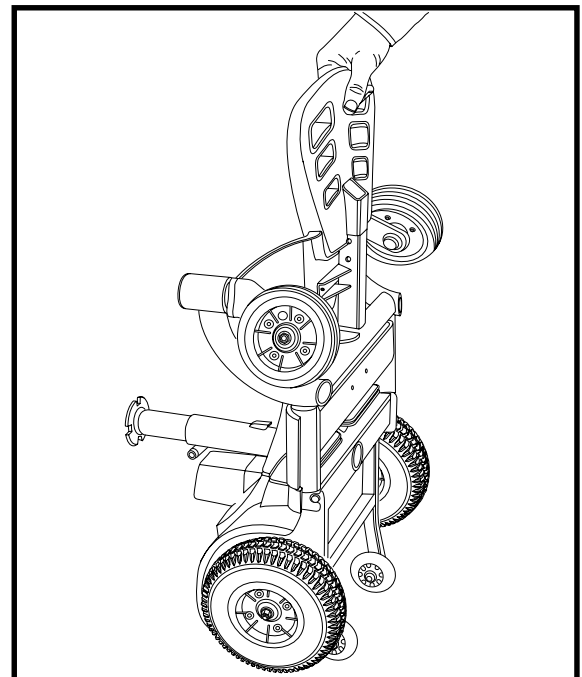

Figure 15. Lift Front Section

V. COMFORT ADJUSTMENTS

COMFORT ADJUSTMENTS

After becoming familiar with your travel chair's operation, you may find the need to make some adjustments to increase your comfort, such as seat height, armrest width, foot platform depth, and controller position. Use the steps below to make comfort adjustments.

WARNING! If your Go-Chair was configured by an authorized Pride Provider, please consult the authorized Pride Provider before changing the seat position or making any other adjustment. Some adjustments may degrade your travel chair's performance and safety by changing its center of gravity.



WARNING! Some Go-Chair components are heavy. You may need assistance to lift or carry them. Please refer to the specifications table for specific component weights before you disassemble the Go-Chair.

WARNING! Prevent injury. Remove the occupant from the Go-Chair before making any adjustments.

Seat Height Adjustment

You can adjust the seat to two different heights in 1-in. increments. Seat height adjustment requires the removal of the battery box.

To change the seat height:

1. Turn off power to the controller. See VII. "Operation."
2. Remove the seat.
3. Remove the battery box.
4. Loosen the quick release fastener. See figure 16.
5. Remove the ball detent pin hardware from the seat pedestal.
6. Reposition the seat pedestal to the desired height.
7. Reinstall the seat pedestal ball detent pin.
8. Tighten the quick release fastener. See figure 17.
9. Reinstall the battery box.
10. Reinstall the seat.
11. Reconnect the controller connector.

Quick Release Fasteners

The quick release fastener removes excess play in the seat pedestal. See figure 16. The quick release fastener consists of a bolt, a lever, and a nut. See figure 17. The lever has a cam on the end that allows it to clamp into place. The quick release fastener has two states: clamped and unclamped. When the lever is open, the quick release fastener is unclamped. When the lever is closed, the quick release fastener is clamped.

To clamp the quick release fastener:

1. Make sure the lever is in the open position.
2. Turn the nut clockwise until it is snug.
3. Rotate the lever until it is in the fully closed position.

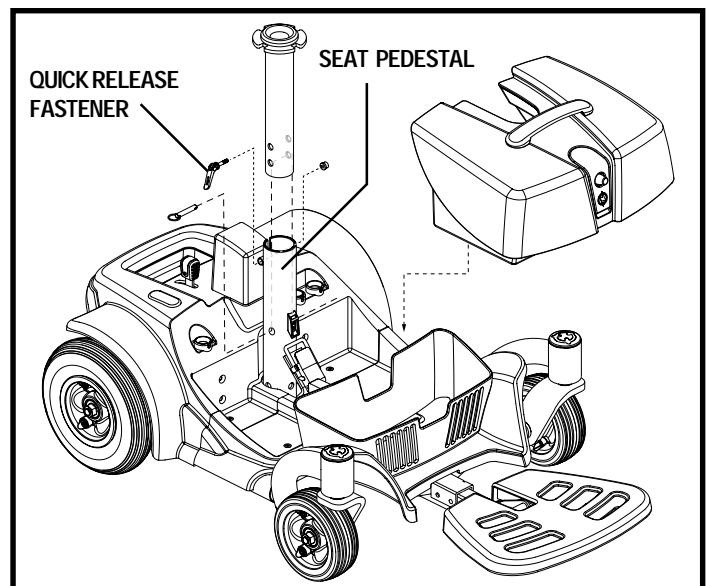

Figure 16. Seat Height Adjustment

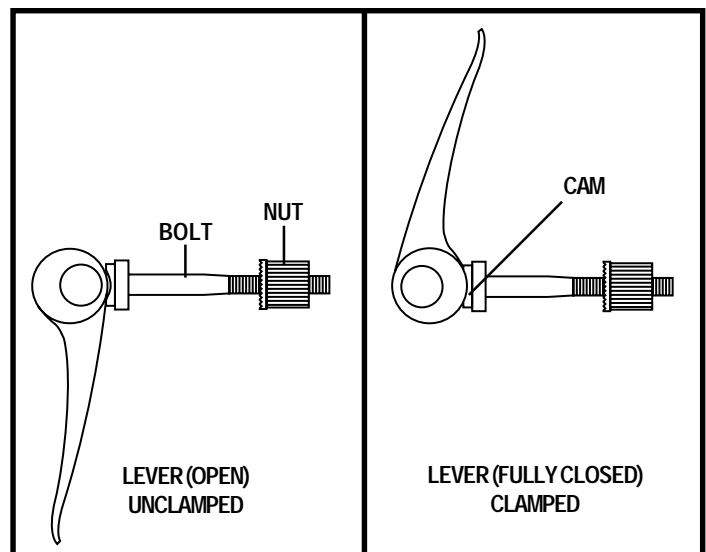

Figure 17. Quick Release Fastener Operation

V. COMFORT ADJUSTMENTS

NOTE: If the lever will not rotate to the fully closed position, then turn the nut counterclockwise one-quarter or one-half turn.

Armrest Width Adjustment

You can change each armrest's width independently of the other.

NOTE: Changing the armrest width may increase the overall width of your Go-Chair.

To change the armrest width:

1. Locate the two armrest knobs on each side of the armrest receiver bracket. See figure 18.
2. Loosen the knobs.
3. Slide the armrests in or out to the desired width.
4. Tighten the knobs.

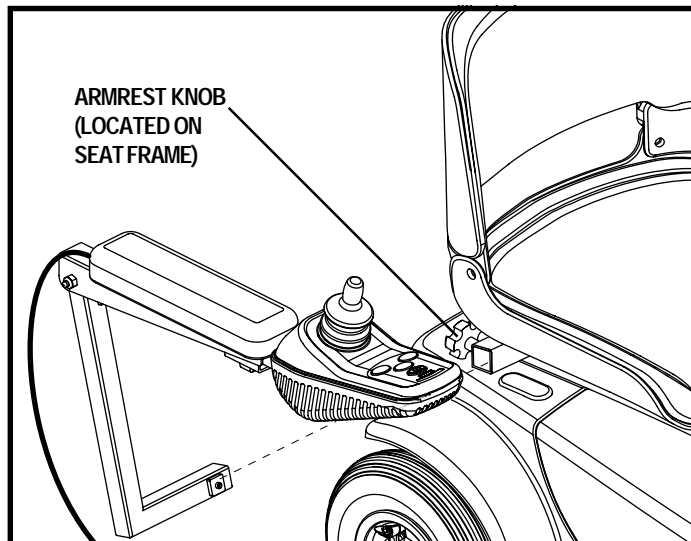

Figure 18. Armrest Width Adjustment

Foot Platform Depth

To adjust the foot platform depth:

1. Remove the hardware from the foot platform bracket. See figure 19.
2. Move the foot platform in or out to the desired depth.
3. Reinstall the hardware into the foot platform bracket and tighten.

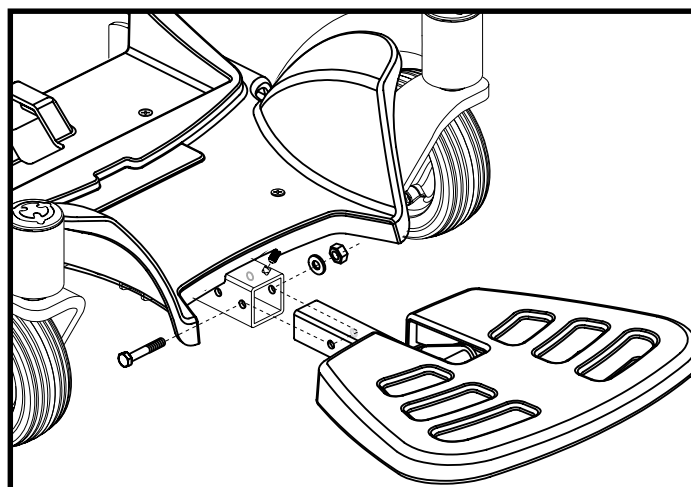

Figure 19. Foot Platform Depth

Controller Position

You can position the controller for either left-hand or right-hand use.



WARNING! Do not place the controller cable so that it can be pinched in the seat frame or the power base frame.

To change the controller position:

1. Unplug the controller connector from the power base.
2. Cut the wire tie(s) securing the controller cable to the armrest.
3. Flip up the armrest and loosen the setscrew. See figure 20.
4. Slide the controller out of the armrest.
5. Loosen the setscrew in the other armrest.
6. Place the controller in the other armrest.
7. Tighten the setscrew to secure the controller.
8. Use a wire tie to secure the controller cable to the armrest.
9. Plug the controller connector into the power base.

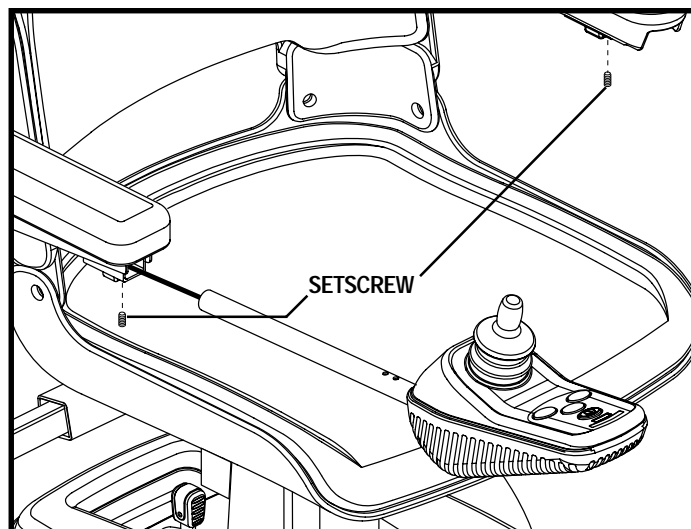

Figure 20. Controller Position

VI. BATTERIES AND CHARGING

BATTERIES AND CHARGING

The Go-Chair uses two long-lasting, 12-volt, deep-cycle batteries. These batteries are sealed and maintenance free. Since they are sealed, there is no need to check the electrolyte (fluid) level. Deep-cycle batteries are designed to handle a longer and deeper discharge. Though they are similar in appearance to automotive batteries, they are not interchangeable. Automotive batteries are not designed to handle a long, deep discharge, and also are unsafe for use in travel chairs.



WARNING! Battery posts, terminals, and related accessories contain lead and lead compounds. Wash hands after handling.

Charging the Batteries

The battery charger is essential in providing long life for your Go-Chair batteries. It is designed to optimize your travel chair's performance by charging the batteries safely, quickly, and easily.



WARNING! You must recharge your travel chair's batteries with the supplied battery charger. Do not use an automotive-type battery charger.



PROHIBITED! Removal of grounding prong can create electrical hazard. If necessary, properly install an approved 3-pronged adapter to an electrical outlet having 2-pronged plug access. Failure to heed could result in personal injury and/or property damage.



PROHIBITED! Never use an extension cord to plug in your battery charger. Plug the charger directly into a properly wired standard wall outlet.

To charge the batteries with the battery box installed on the power base:

1. Position your Go-Chair next to a standard wall outlet. See figure 21.
2. Turn off the power to the controller.
3. Plug the off-board charger into the off-board charger socket on the controller. See figure 21. Refer to VII. "Operation" for more information.
4. Plug the off-board charger into the wall outlet. See figure 21.

NOTE: If it is a Pride off-board charger, then there are two LEDs in it. Refer to the supplied charger manual for information on LED indications. If it is not a Pride off-board charger, then follow the instructions supplied by the manufacturer.

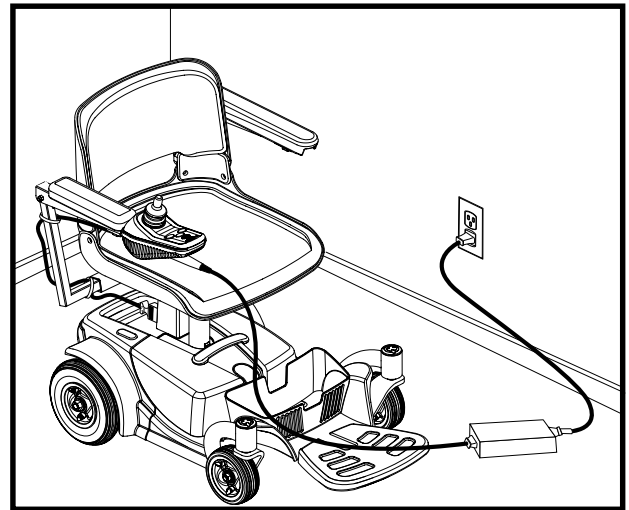

Figure 21. Battery Charging (Battery Box Installed)

5. When the batteries are fully charged, unplug the off-board charger from the wall outlet and then from the controller.

To charge the batteries with the battery box removed from the power base:

1. Remove the battery box from the power base. See IV. "Assembly/Disassembly."



WARNING! Prevent product damage! Do not remove the basket to access the battery box or battery box charger port.

2. Position the battery box next to a standard wall outlet.
3. Plug the off-board charger into the battery box charger port.

VI. BATTERIES AND CHARGING



WARNING! Prevent product damage! Use the battery box charging port for battery charging only after the battery box has been completely removed from the Go-Chair.

4. Plug the off-board charger into the wall outlet.

NOTE: *If it is a Pride off-board charger, then there are two LEDs in it. Refer to the supplied charger manual for information on LED indications. If it is not a Pride off-board charger, then follow the instructions supplied by the manufacturer.*

5. When the batteries are fully charged, unplug the off-board charger from the wall outlet and then from the battery box.
6. Reinstall the battery box to the power base.

Battery Break-in

To break in new batteries for maximum efficiency:

1. Fully recharge any new battery prior to its initial use. This brings the battery up to about 90% of its peak performance level.
2. Operate your Go-Chair throughout the house and yard. Move slowly at first, and don't travel too far until you become accustomed to the controls and break in the batteries.
3. Give the batteries another full charge of 8 to 14 hours and operate your Go-Chair again. The batteries will now perform at over 90% of their potential.
4. After four or five charging cycles, the batteries will top off at 100% charge and last for an extended period.

Frequently Asked Questions (FAQs)

How does the charger work?

The battery charger takes the standard wall outlet voltage of 120 VAC (alternating current) and converts it to 24 VDC (direct current). The Go-Chair batteries use direct current to run your Go-Chair. When the battery voltage is low, the charger works harder to charge the battery).

Can I use a different battery charger?

You should use the charger supplied with the Go-Chair. It is the safest, most efficient tool to charge the batteries. We do not recommend using other types of chargers (e.g., an automotive battery charger).

NOTE: *Your travel chair's charger will not operate after the batteries have been discharged to nearly zero voltage. If this happens, call an authorized Pride Provider for assistance.*

How often must I charge the batteries?

Many factors come into play when deciding how often to charge the batteries. You may use your Go-Chair all day on a daily basis or you may not use it for weeks at a time.

■ Daily Use

If you use your Go-Chair on a daily basis, charge the batteries as soon as you are finished using your Go-Chair. Your Go-Chair will be ready each morning to give you a full day's service. It is recommended that you charge the batteries 8 to 14 hours after daily use.

■ Infrequent Use

If you use your Go-Chair infrequently (once a week or less), you should charge the batteries at least once per week for 12 to 14 hours.

VI. BATTERIES AND CHARGING

NOTE: *Keep your batteries fully charged and avoid deeply discharging your batteries. Do not charge the batteries for more than 24 hours at a charging cycle.*

How can I get maximum range or distance per charge?

Rarely do you have an ideal driving situation such as smooth, flat, hard terrain with no wind, hills, or curves. More often you are presented with hills, sidewalk cracks, uneven and loosely packed surfaces, curves, and wind. All of these factors will affect the distance or running time per battery charge. Below are a few suggestions for obtaining the maximum range per charge:

- Always charge the batteries fully prior to your trip.
- Plan your trip in advance to avoid inclines if possible.
- Limit baggage weight to essential items.
- Try to maintain an even speed and avoid stop-and-go driving.

What type of batteries should I use?

We recommend deep-cycle batteries that are sealed and maintenance free. Both AGM and Gel-Cell are deep-cycle batteries that are similar in performance. Refer to the Specifications Table for more information regarding the batteries used with your Go-Chair.



WARNING! Corrosive chemicals contained in batteries. Use only AGM or Gel-Cell batteries to reduce the risk of leakage or explosive conditions.

Why do my new batteries seem weak?

Deep-cycle batteries employ a much different chemical technology than that used in car batteries, nickel-cadmium (nicads), or in other common battery types. Deep-cycle batteries are specifically designed to provide power, drain down their charge, and then accept a relatively quick recharge. AGM and Gel-Cell batteries should be charged as often as possible. They do not have a “memory” like nickel-cadmium batteries.

We work closely with our battery manufacturer to provide a battery that best suits your travel chair’s specific demands. Fresh batteries arrive regularly at Pride and are promptly shipped with a full charge. During shipping, the batteries encounter temperature extremes that may influence initial performance. Heat robs the charge from the battery, and cold slows the power available and extends the time needed to recharge the battery (just as with a car battery).

It might take a few days for the temperature of the battery to stabilize and adjust to its new ambient temperature. More importantly, it will take a few “charging cycles” (a partial drain— then a full recharge) to establish the critical chemical balance that is essential to the battery’s peak performance and long life. It will be well worth it to take the time to break in your battery properly.

How can I ensure maximum battery life?

A fully charged deep-cycle battery will provide reliable performance and extended battery life. Keep your travel chair’s batteries fully charged whenever possible. Batteries that are regularly and deeply discharged, infrequently charged, or stored without a full charge may be permanently damaged, causing unreliable Go-Chair operation and limited battery life.

VI. BATTERIES AND CHARGING

How should I store my Go-Chair and its batteries?

If you do not use your Go-Chair regularly, we recommend maintaining battery vitality by charging the batteries at least once per week.

If you do not plan on using your Go-Chair for an extended period, fully charge the batteries prior to storage. Disconnect the battery harnesses and store the Go-Chair in a warm, dry environment. Avoid temperature extremes, such as freezing and excessively hot conditions, and never attempt to charge a frozen battery. A cold or frozen battery should be warmed for several days prior to recharging.

What about public transportation?

AGM and Gel-Cell batteries are designed for application in travel chairs and other mobility vehicles. These batteries are Federal Aviation Administration (FAA) approved, allowing safe transportation on aircraft, buses, and trains, as there is no danger of spillage or leakage. We suggest you contact the carrier's ticket counter in advance to determine that carrier's specific requirements.

What about shipping?

If you wish to use a freight company to ship your Go-Chair to your final destination, repack your Go-Chair in the original shipping container and ship the batteries in separate boxes.

VII. OPERATION

VSI CONTROLLER

The electronic controller is what you use to operate your Go-Chair. It takes the battery voltage and sends it to the appropriate system. The electronic controller enables you to move the Go-Chair, as well as monitor battery charge, electronic controller functions, and the condition of your electrical system. The VSI controller is an integral electronic controller. All of the electronics necessary to operate the Go-Chair are contained in one module. See figure 22. Typically, the VSI is mounted to one of the armrests and is connected to the motors and batteries on the power base.

The VSI consists of:

1. joystick
2. keypad
3. off-board charger socket
4. controller connector

Joystick

The joystick controls the direction and speed of your Go-Chair. When you move the joystick from the neutral (center) position, the electromagnetic brakes release and allow your Go-Chair to move. The farther you push the joystick from its neutral position, the faster your Go-Chair moves. When you release the joystick and allow it to return to the neutral position, you engage the electromagnetic brakes. This causes your Go-Chair to decelerate and come to a complete stop.



WARNING! If your Go-Chair begins to move in an unexpected manner, immediately release the joystick. Unless the joystick is damaged, this action should stop your Go-Chair.

Keypad

The keypad is located in front of the joystick. It contains keys necessary to operate your Go-Chair. See figure 23.

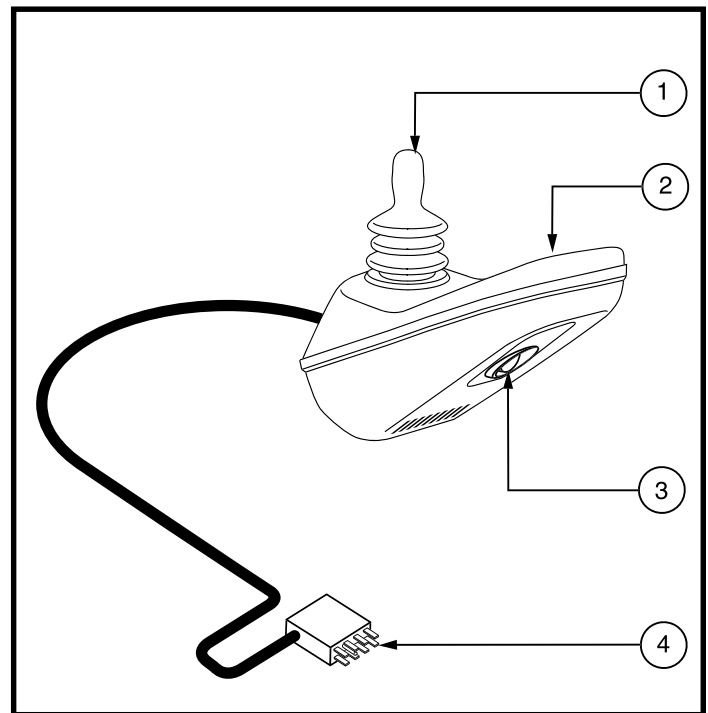

Figure 22. VSI Controller

VII. OPERATION

On/Off Key

The on/off key turns the VSI on and off.



WARNING! Unless faced with an emergency situation, do not use the on/off key to stop the chair. This will cause the Go-Chair to stop abruptly.

WARNING! Always turn the power off when you are stationary to prevent unexpected movement.

Battery Condition Meter

The battery condition meter is located in front of the joystick. This is a 10-segment illuminated display that indicates that the VSI is turned on and also gives the battery status, the VSI status, and the electrical system status.

- **Red, yellow, and green lights lit:** Batteries charged; VSI and electrical system OK.
- **Red and yellow lights lit:** Charge batteries if possible; VSI and electrical system OK.
- **Red lights only lit or slow flash:** Charge batteries as soon as possible; VSI and electrical system OK.
- **Rapid flash of lights:** Indicates a fault in the VSI or the electrical system. Refer to “VSI Error Codes.”
- **Ripple side to side of lights:** The joystick was not in the neutral position when the controller was turned on. If you get “ripple side to side of lights,” turn off the controller, allow the joystick to return to the neutral position, then turn on the controller.

NOTE: If you still get “ripple side to side of lights,” contact an authorized Pride Provider.

NOTE: When the batteries approach a discharged state, the first red light will begin to slowly flash, reminding you the batteries need to be charged immediately!

Speed Keys

The speed key controls the speed. Press the speed increase key to increase the speed. Press the speed decrease key to decrease the speed. The speed setting is displayed on the maximum speed indicator.

NOTE: We recommend that the first few times you operate your Go-Chair, you set the speed to the slowest setting until you become familiar with your new Go-Chair.

Horn Key

The horn key activates the horn.

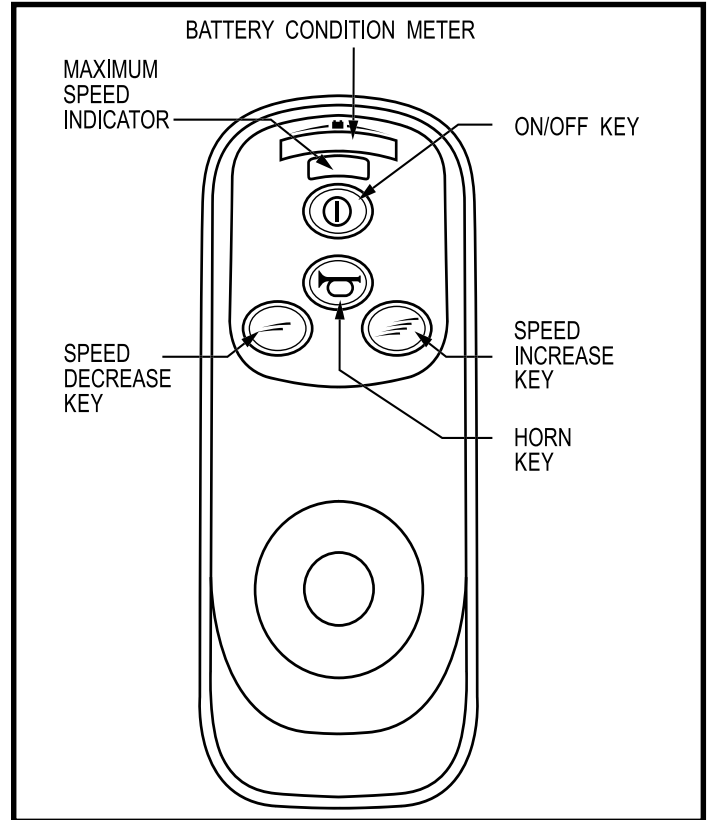

Figure 23. VSI Controller Keypad

VII . O P E R A T I O N

Locking/Unlocking the VSI

The VSI has a feature that enables you to lock your Go-Chair to prevent unauthorized use.

To lock the VSI:

1. With the VSI switched on, press and hold the on/off key. After 1 second, the VSI should beep.
2. Release the on/off key.
3. Push the joystick to the full forward position until the VSI beeps.
4. Pull the joystick to the full rearward position until the VSI beeps.
5. Release the joystick. There should be a long beep.
6. The VSI is now locked.

To unlock the VSI:

1. Press the on/off key and power on the VSI. The maximum speed/profile indicator should ripple side to side.
2. Push the joystick to the full forward position until the VSI beeps.
3. Pull the joystick to the full rearward position until the VSI beeps.
4. Release the joystick. There should be a long beep.
5. The VSI is now unlocked.

NOTE: *If the above procedure fails to either lock or unlock the VSI, contact an authorized Pride Provider.*

Off-board Charger Socket

You may use an off-board charger to charge the Go-Chair batteries through the 3-pin socket located on the front of the VSI. The off-board charger current should not exceed 5 amps. Contact an authorized Pride Provider for more information.



WARNING! Only authorized Pride chargers should be connected to the off-board charger socket. See an authorized Pride Provider for more information.

NOTE: *The off-board charger socket on the controller should be used when charging the batteries with the battery box installed on the power base.*

Controller Connector

This connects the VSI to the travel chair's batteries, motors, and motor brakes.

Sleep Mode

The VSI controller is equipped with a sleep mode feature. Sleep mode is a built-in circuit that automatically shuts off the main power if the joystick is not moved in any direction for a preset period of time. The battery condition meter lights on the keypad indicate sleep mode by blinking once every five seconds. To restore power and continue, push the on/off key twice.

VII . O P E R A T I O N

Thermal Rollback

The VSI controller is equipped with a thermal rollback circuit. This circuit monitors the temperature of the controller, which roughly translates to motor temperature. In the event that the VSI controller becomes excessively hot (above 140° F), motor current (amperage) is reduced. For every degree above 131° F, the motor current limit is reduced by .55 amps. This reduces your Go-Chair's "power," which could also reduce your Go-Chair's speed. Once the VSI controller reaches 158° F, the current output is reduced to zero and your Go-Chair will stop. This allows the electrical components and motors to cool down. When the temperature returns to a safe level, your Go-Chair resumes its normal operation.

VSI Error Codes

The VSI controller is designed with the user's safety as the prime consideration. It incorporates many sophisticated self-test features which search for potential problems at a rate of 100 times per second. If the VSI detects a problem either in its own circuits or in the travel chair's electrical system, it may decide to stop the Go-Chair, depending on the severity of the problem. The VSI is designed to maximize the user's safety under all normal conditions. The table below identifies the individual error codes. Error codes are displayed as a rapid flashing of the lights. If you get one of these error codes, contact an authorized Pride Provider.

FLASHING LIGHTS	DIAGNOSIS AND SOLUTION
1	The batteries need charging or there is a bad connection to the batteries. Check the connections to the batteries. If the connections are good, try charging the batteries.
2	The left motor has a bad connection. Check the left motor connection.
3	The left motor has a short circuit to a battery connection. Contact an authorized Pride Provider.
4	The right motor has a bad connection. Check right motor connection.
5	The right motor has a short circuit to a battery connection. Contact an authorized Pride Provider.
6	The Go-Chair is being inhibited by the battery charger. Unplug the battery charger.
7	A joystick fault is indicated. Make sure that the joystick is in the neutral (center) position before turning on the controller.
8	A controller system fault is indicated. Make sure that all connections are secure.
9	The parking brakes have a bad connection. Check the parking brake and motor connections. Make sure the controller connections are secure.
10	An excessive voltage has been applied to the controller. This is usually caused by a poor battery connection. Check the battery connections.

VIII. CARE AND MAINTENANCE

CARE AND MAINTENANCE

Your Go-Chair is a sophisticated travel mobility vehicle. Like any motorized vehicle, it requires routine maintenance checks. You can perform some of these checks, but others require assistance from an authorized Pride Provider. Preventive maintenance is very important. If you follow the maintenance checks in this section as scheduled, you can help ensure that your Go-Chair gives you years of trouble-free operation. If you have any doubt as to your travel chair's care or operation, contact an authorized Pride Provider.



WARNING! Prevent injury. Do not service the Go-Chair when the seat is occupied.

Your Go-Chair, like most electrical equipment, is susceptible to damage from the elements. Avoid damp areas of any kind.



WARNING! Direct exposure to water or dampness could cause the Go-Chair to malfunction electronically and mechanically. Water can cause electrical components to corrode and the chair's frame to rust.

Should your Go-Chair come in contact with water:

1. Dry your Go-Chair as thoroughly as possible with a towel.
2. Allow your Go-Chair to sit in a warm, dry place for 12 hours to allow unseen water to evaporate.
3. Check the joystick operation and the brakes before using your Go-Chair again.
4. If any inconsistencies are found, take your Go-Chair to an authorized Pride Provider.

Temperature

- Some of the parts of your Go-Chair are susceptible to extreme changes in temperature. Always keep your Go-Chair between the temperatures of 18° F and 122° F.
- In extremely cold temperatures the batteries may freeze. The specific temperature at which they freeze depends on a number of factors, such as battery charge, usage, and composition of the batteries (e.g., AGM or Gel-Cell).
- Temperatures above 122° F may cause your Go-Chair to operate at a reduced speed. This reduced speed is a safety feature built into the controller that helps prevent damage to the motor and other electrical components. See VII. "Operation."

General Guidelines

- Avoid knocking or bumping the controller, especially the joystick.
- Avoid prolonged exposure of your Go-Chair to extreme conditions, such as heat, cold, or moisture.
- Keep the controller clean.
- Check all connectors to ensure that they are all tight and secured properly.
- Use a rubber conditioner on the tire sidewalls to help preserve them.



WARNING! Never use a rubber conditioner on the tread area of the tires; doing so may make the tires slippery and cause your Go-Chair to skid.

- The body shroud has been sprayed with a clear sealant coating. You can apply a light coat of car wax to help it retain its high-gloss appearance.
- Check all electrical connections. Make sure they are tight and are not corroded. Batteries must sit flat within the battery tray, with the battery terminals facing inward, toward each other. Refer to the battery wiring label for the correct wiring layout.
- All wheel bearings are prelubricated and sealed. They require no subsequent lubrication.

VIII. CARE AND MAINTENANCE

Daily Checks

- With the controller turned off, check the joystick. Make sure it is not bent or damaged and that it returns to the neutral position when you release it. Check the rubber boot around the base of the joystick for damage. Visually inspect the boot. Do not handle or try to repair it. See an authorized Pride Provider if there is a problem.
- Visually inspect the controller cable. Make sure that it is not frayed, cut, or has any wires exposed. See an authorized Pride Provider if there is a problem.
- Check for flat spots on solid tires. Flat spots could adversely affect stability.

Weekly Checks

- Disconnect and inspect the controller from the power base. Look for corrosion. Contact an authorized Pride Provider if necessary.
- Ensure that all parts of the controller system are securely fastened to your Go-Chair. Do not overtighten any screws.
- Calibrate the joystick if a noticeable difference in performance is detected or if the joystick does not operate properly. To calibrate the joystick, power off the unit, place the joystick in the neutral position, and power the unit back on. If a problem still exists with your joystick's performance, contact an authorized Pride Provider.
- Check the brakes. This test should be carried out on a level surface with at least three feet of clearance around your Go-Chair.

To check the brakes:

1. Turn on the controller and turn down the speed level of your Go-Chair.
2. After one second, check the battery condition meter. Make sure that it remains on.
3. Slowly push the joystick forward until you hear the electric brakes click. Immediately release the joystick. You must be able to hear each electrical brake operating within a few seconds of joystick movement. Repeat this test three times, pushing the joystick backwards, then left, and then right.

Monthly Checks

- Check for drive tire wear. See an authorized Pride Provider for repair.
- Check the caster wheels for wear. Replace them as necessary.
- Check the caster forks for damage or fluttering which indicates that they may need to be adjusted or have the bearings replaced. See an authorized Pride Provider for repair.
- Keep your Go-Chair clean and free of foreign material, such as mud, dirt, hair, food, drink, etc.

Yearly Checks

Take your Go-Chair to an authorized Pride Provider for yearly maintenance. This helps ensure that your Go-Chair is functioning properly and helps prevent future complications.

Storage

Your Go-Chair should be stored in a dry place, free from temperature extremes. When storing, disconnect the batteries from the Go-Chair. See VI. "Batteries and Charging."



WARNING! If you fail to store the unit properly, the frame can rust and the electronics can be damaged.

Cleaning Instructions



WARNING! Never hose off your Go-Chair or place it in direct contact with water. Your Go-Chair has a painted, ABS plastic body shroud that allows it to be easily wiped clean with a damp cloth.

VIII. CARE AND MAINTENANCE



WARNING! Never use any chemicals to clean a vinyl seat, as they may cause the seat to become slippery or dry out and crack. Use soapy water and dry the seat thoroughly.

Wheel Replacement

If your chair is equipped with a solid tire insert, then you must replace the whole wheel assembly. Replacement wheel assemblies are readily available through an authorized Pride Provider.



WARNING! To avoid possible injury, be sure that the controller's power is turned off and the Go-Chair is not in freewheel mode before performing this procedure.

To replace the wheel:

1. Turn off the power to the controller.
2. Set the Go-Chair up on blocks.
3. Remove the drive wheel nut from the wheel hub. See figure 24.
4. Pull the wheel off the axle.
5. Slide the new wheel back onto the shaft. Make sure that the key is in the axle slot.
6. Reinstall the drive wheel nut onto the wheel hub and tighten.
7. Remove the Go-Chair from the blocks.

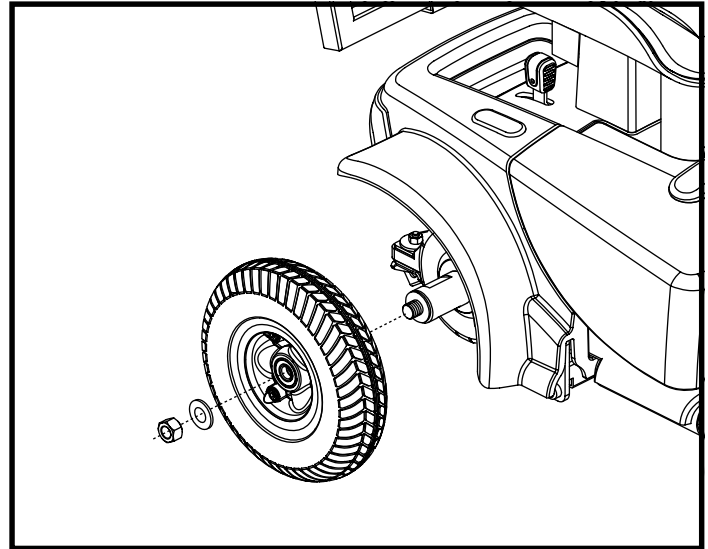

Figure 24. Go-Chair Drive Wheel

Battery Replacement

A battery wiring diagram is printed on a decal located on the front battery tray. See the Specifications Table for correct battery specifications.

WARNING! Prevent injury. Do not replace battery when seat is occupied.



WARNING! Battery posts, terminals, and related accessories contain lead and lead compounds. Wear goggles and gloves when handling batteries and wash hands after handling.

WARNING! Go-Chair batteries are heavy. See specifications table. If you are unable to lift that much weight, be sure to get help. Lifting beyond your capacity can result in personal injury.

To replace the batteries:

1. Remove the battery box from the Go-Chair.
2. Turn the pack upside down.
3. Remove all screws that hold the battery box halves together. See figure 25.
4. Flip the battery box back over so the handle is up and remove the lid.
5. Remove the red (+) positive and black (-) negative battery leads from each battery.
6. Remove the batteries.
7. Put the new battery or batteries back into the battery box (battery terminals up).
8. Reconnect the two (2) battery leads to the battery terminals. Make sure the red lead is connected to the (+) positive terminal and the black lead is connected to the (-) negative terminal.
9. Replace the lid and carefully flip the battery box over so the handle is down.
10. Replace and tighten all the screws that hold the battery box together.
11. Reinstall the battery box back onto the Go-Chair.

VIII. CARE AND MAINTENANCE

When to See An Authorized Pride Provider for Service

The following symptoms could indicate a serious problem with your Go-Chair. If necessary, contact an authorized Pride Provider. When calling, have the model number, serial number, nature of the problem, and the error code if available.

- Motor noise
- Frayed harnesses
- Cracked or broken connectors
- Uneven wear on any of the tires
- Jerky motion
- Pulling to one side
- Bent or broken wheel assemblies
- Does not power up
- Powers up, but does not move

Corrective Maintenance

If the battery condition meter does not light up when you turn on the power:

- Check the harness connections. Make sure they are tight.
- Check the circuit breaker. Reset it if necessary.
- Check the battery connections.

If the above conditions prove normal, you can load test the batteries with a battery load tester. These testers are available at automotive parts stores. Disconnect both batteries before load testing and follow the directions that come with the load tester. If either one of the batteries fails the load test, replace both of them. If your Go-Chair still does not power up, contact an authorized Pride Provider.

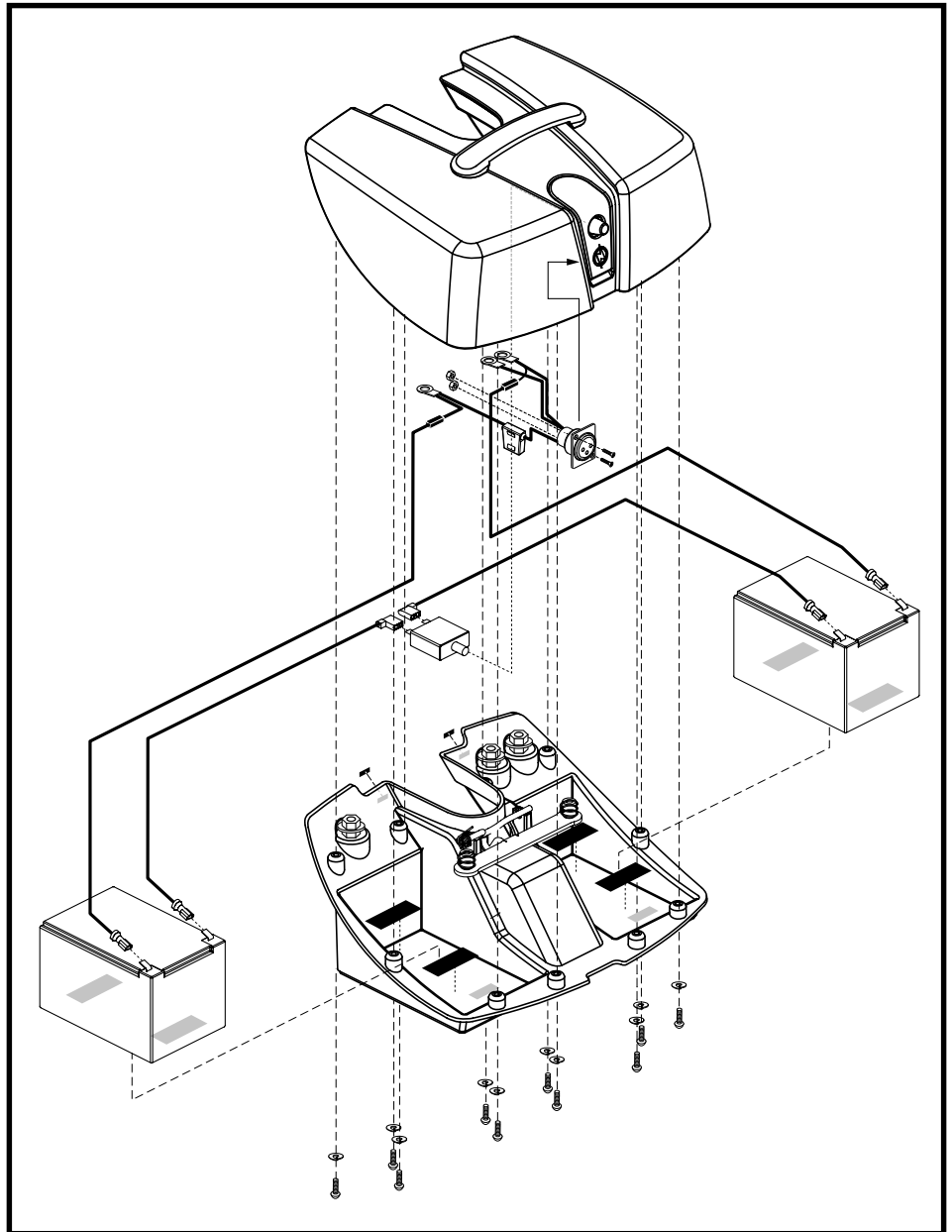

Figure 25. Go-Chair Battery Box

I X . W A R R A N T Y

FIVE-YEAR LIMITED WARRANTY

For five (5) years from the date of purchase, Pride will repair or replace at our option to the original purchaser, free of charge, any of the following parts found upon examination by an authorized representative of Pride to be defective in material and/or workmanship:

Structural frame components, including:

- Main Frame
- Seat Post

ONE-YEAR LIMITED WARRANTY

For one (1) year from the date of purchase, Pride will repair or replace at our option to the original purchaser, free of charge, any of the following parts found upon examination by an authorized representative of Pride to be defective in material and/or workmanship:

Electronic components, including:

- Charger Assembly
- Controller
- Joystick

Main frame assemblies, including:

- Anti-tip forks
- Caster forks
- Metal seat framing
- Accessories

Other components, including:

- Brakes (electronic function ONLY)
- Motor/gearbox assembly
- Bearings and bushings
- Plastic components, excluding body
- Electrical Harness
- Foot rigging mounting brackets

SIX-MONTH LIMITED WARRANTY

■ Battery: The battery is covered by a separate six-month warranty, provided by the battery manufacturer. The batteries are not warranted by Pride.

RECONDITIONED UNITS WARRANTY

All reconditioned units are covered by a six-month warranty from Pride effective from the date of purchase.

WARRANTY EXCLUSIONS

- ABS Plastic shrouds and footrests
- Motor brushes
- Upholstery and seating
- Brake pads (wear items)
- Fuses
- Tires and tubes (wear items)
- Circumstances beyond the control of Pride
- Labor, service calls, shipping, and other charges incurred for repair of the product, unless specifically authorized by Pride Mobility Products Corporation
- Repairs and/or modifications made to any part without specific consent from Pride

Exclusions also include components with damage caused by:

- Contamination
- Abuse, misuse, accident, or negligence
- Battery fluid spillage or leakage
- Commercial use, or use other than normal
- Improper operation, maintenance, or storage

I X . W A R R A N T Y

SERVICE CHECKS AND WARRANTY SERVICE

Warranty service must be performed by an authorized Pride Provider. Do not return faulty parts to Pride without prior written authorization. All transportation costs and shipping damage incurred while submitting parts for repair or replacement are the responsibility of the purchaser.

Failure to follow the instructions, warnings, and notes in the owner's manual and those located on your Pride product can result in personal injury or product damage and will void Pride's product warranty.

There is no other express warranty.

IMPLIED WARRANTIES

Implied warranties, including those of merchantability and fitness for a particular purpose, are limited to one (1) year from the date of purchase and to the extent permitted by law. Any and all implied warranties are excluded. This is the exclusive remedy. Liabilities for consequential damages under any and all warranties are excluded.

Some states do not allow limitations on how long an implied warranty lasts or do not allow the exclusion of limitation incidental or consequential damages. The above limitation or exclusion may not apply to you.

This warranty gives you specific rights, and you may also have other rights which vary from state to state.

Please fill out and return the product registration card to Pride. This will aid Pride in providing the best possible technical and customer service.

NOTES



The First Name in Travel Mobility™
Quality Control - Go-Chair



Thank you for making the Go-Chair your choice in travel mobility.

We have thoroughly inspected your Go-Chair. The following checkmarks indicate that it has been test driven and inspected.



Joystick Serial #

Controller Serial #

Inclusion of
all Parts

Fit and Finish

Performance

Pride keeps a more detailed report on file at the factory.

Date Inspected

Inspector

Serial Number